



PEGAMO

RAILWAY DEPOT EQUIPMENT



PEGAMO has been applying the latest technologies in Train Depot Equipments for more than 30 years now. Three decades of experience and continuous development give us the chance to offer to our customers the best solutions for train manufacturing and its maintenance.

The wide range of equipment required for manufacturing, repairing and maintenance of railway rolling stock, demands the warranty of choosing the best technical choice. Because of this reason, Pegamo works actively with their customers designing, developing and manufacturing all the requiring equipments for each project.

Pegamo also cooperates with international companies, in order to offer complete solutions for such a dynamic and highly demanding market.





// EXPERIENCE
AND INNOVATION

PRODUCTS

LIFTING JACKS

LIFTING EQUIPMENTS

- Bogie drops
- Rail drops
- Bogie lifting tables
- Lifting platforms

HANDLING DEVICES

- Bogie frame rotators
- Bogie turntables
- Pushers
- Transporters

PRESSES

- Bogie presses
- Assembly and auxiliary presses

TESTING BENCHES

- Bogie predictive maintenance
- Wheelset measurement
- Spring calibration

SAND FILLING SYSTEMS

- Silos
- Dispensing stations
- Mobile units

LIFTING JACKS

LIFTING CAPACITY:

- Up to 45 tonne jacks

LEVELLING CONTROL

FIXED OR MOVING ANVIL

EXCLUSIVE ELECTRONIC CONTROL

- Remote assistance via Internet
- Event storing and recording
- Possible to control up to 128 jacks
- Self programmed maintenance (optional)
- 20% energy saving (INVERTER)
- Configuration from 4 to 128 jacks
- Remote technical support

CUSTOM TAILORED SOLUTIONS

BOGIE HANDLING

FIXED OR WITH LIFTING DEVICE:

from 5 up to 30 tonnes

FOR BOGIES, CAR BODIES

OR ELEMENT

CUSTOMIZED GRIPPER TOOLS

CUSTOM TAILORED SOLUTIONS

LIFTING JACKS

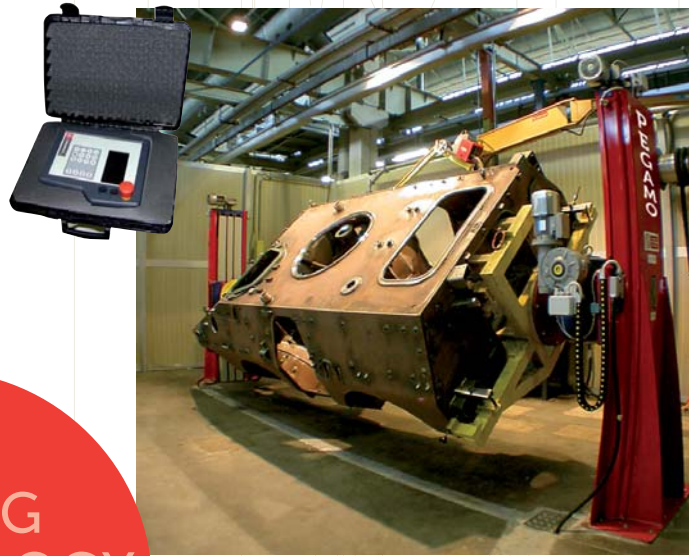
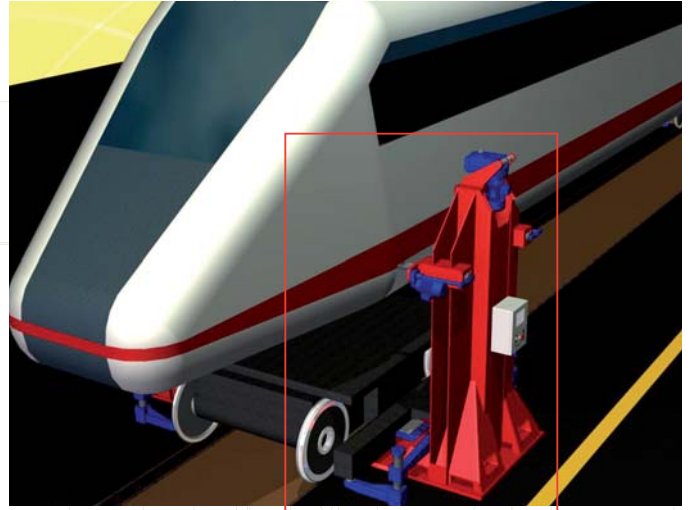

LIFTING TECHNOLOGY

LIFTING EQUIPMENT

BOGIE DROPS:

LIFTING SYSTEMS

- Electromechanical jacks
- Hydraulic scissors

CUSTOM TAILORED SOLUTIONS

- Load capacities
- Accesses for bogie maintenance
- Low depth pits

RAIL DROPS

CUSTOM TAILORED SOLUTIONS

- Up to 6 metres of rail length
- Load capacities
- Built-in lifting tables



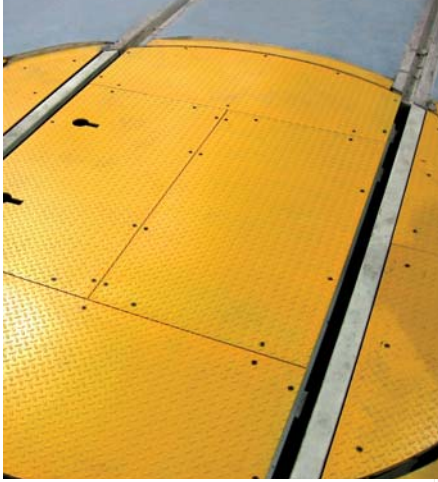

TABLES AND PLATFORMS

SCISSORS LIFTING TABLES

- For handling under vehicles
- Manual or motorized translations
- Batteries or network run

WORKING PLATFORM

- For side or roof acces
- From 250 Kg. of capacity
- Custom tailored solutions

LOAD TRANSPORTER TROLLEYS

- Different load capacities
- Steering or rail guidance
- Batteries or network run
- Remote or radio control
- Custom tailored solutions

BOGIE TURNTABLES

- Electrically powered
- Single or double cross rails

PUSHERS

- For bogies and car bodies



PUSHERS

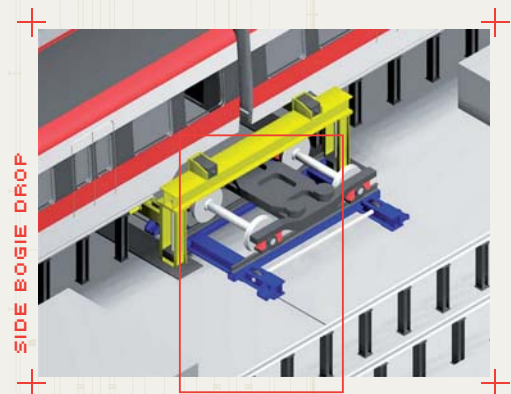

SIDE BOGIE DROP

SAND FILLING SYSTEMS

SAND STORAGE, DISTRIBUTION AND LOADING EQUIPMENT

- Storage silos
- Pneumatic pumping
- Dust return systems
- Mobile distribution units



STRENGTH AND CONTROL

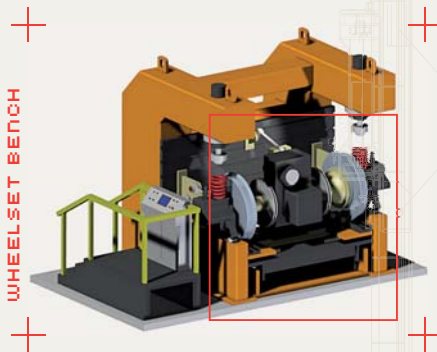

SPRING CALIBRATION

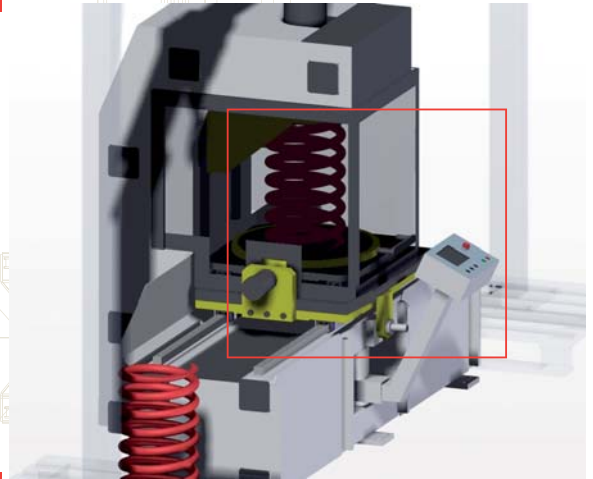

PRESSES AND TESTING BENCHES

BOGIE PRESSES

- Single or twin cylinders
- Load distribution verification
- PLC controlled

WHEEL PRESSES

- Mounting and/or dismantling
- Measuring device
- From 100 up to 600 tonnes

ASSEMBLY AND AUXILIARY PRESSES

- Wide range available

PREDICTIVE MAINTENANCE BENCHES

- Vibration analysis
- On rail simulations

SPRING PRESSES

- Data recording
- PLC controlled

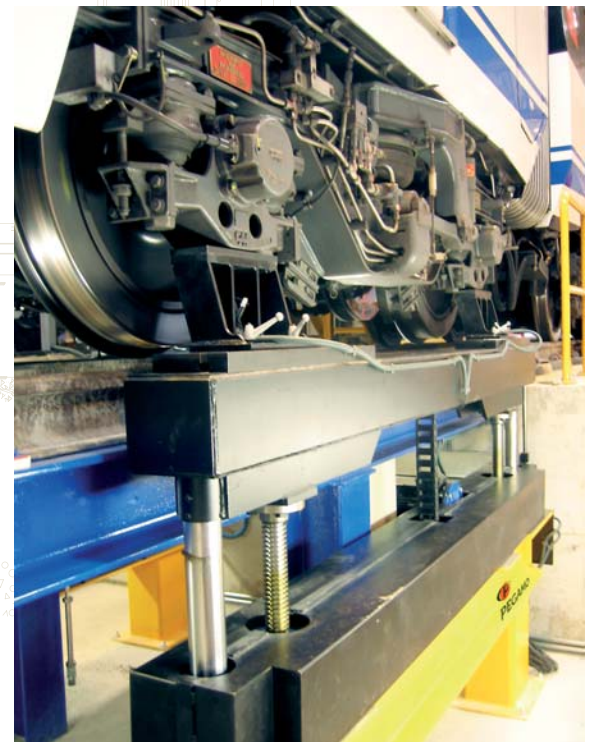



INTEGRAL SERVICE SOLUTIONS PROVIDERS

PEGAMO GROUP is divided into three different Divisions which in turn, are completely independent companies. The three main activities of the GROUP are: Railway Depot Equipment, Industrial Supplies and Fork-lifts.

Due to this variety of markets, PEGAMO Railway Depot Equipment, is able to offer an extensive range of common products and services to several industrial processes, such as:

- Technical advice
- Special machinery manufacture
- Complete depot equipment
- Maintenance
- After-sales service

PEGAMO GROUP works everyday in order to keep the confidence our customers have placed on our firm these last 30 years.

“ ASSISTANCE AND SERVICE





PEGAMO

Barrio Txiki Erdi, s/n
20170 Usurbil
Gipuzkoa - SPAIN
Phone: 0034 943 37 30 11
Fax: 0034 943 37 10 01
www.pegamo.es
railway@pegamo.es

Papel certificado FSC. Mixed Sources:
60% fibras recicladas. 40% fibras vírgenes.

Diseñado por: **adrede**[®]
www.adredecm.com



RAILWAY DEPOT
EQUIPMENT



INDUSTRIAL
SUPPLIES



FORK-LIFTS